

Experience



the Hi-Lite Advantage

25K Aluminum Shoring System Safety Manual



THIS ENGINEERING MANUAL IS SUBJECT TO PERIODIC REVISION AND UPDATING. BEFORE DESIGNING ANY SHORING AND FORMING SYSTEM USING HI-LITE SYSTEMS EQUIPMENT, CONTACT HI-LITE SYSTEMS ENGINEERING DEPARTMENT @ 905-677-4032 TO ENSURE YOU ARE USING THE MOST RECENT REVISION OF THIS MANUAL.

WARNING!

USE OF THIS PRODUCT DATA AND INFORMATION IS FOR THE SOLE AND EXCLUSIVE USE BY TECHNICALLY QUALIFIED INDIVIDUALS WITH APPROPRIATE EDUCATION, TRAINING AND EXPERIENCE, WITH GENERAL FORMING AND SHORING DESIGN PRINCIPLES AND ENGINEERING DESIGN FUNDAMENTALS.

FAILURE TO FOLLOW PROPER PROCEDURE, BOTH AS SET FORTH IN THIS GUIDE AND IN ACCORDANCE WITH APPROVED ENGINEERING PLANS, AND GOOD AND SAFE CONSTRUCTION PRACTICES, CAN LEAD TO DEATH, SERIOUS BODILY INJURY, OR PROPERTY DAMAGE.

THE INFORMATION CONTAINED IN THIS SUPPLEMENT MUST BE CAREFULLY FOLLOWED. FAILURE TO COMPLY WITH THE INFORMATION, GUIDELINES AND SUGGESTIONS IN THIS SUPPLEMENT MAY RESULT IN DEATH, SERIOUS BODILY INJURY OR PROPERTY DAMAGE.

IF YOU ARE IN DOUBT OR IN NEED OF TECHNICAL ASSISTANCE OR ADVICE YOU MUST CONTACT HI-LITE SYSTEMS ENGINEERING.



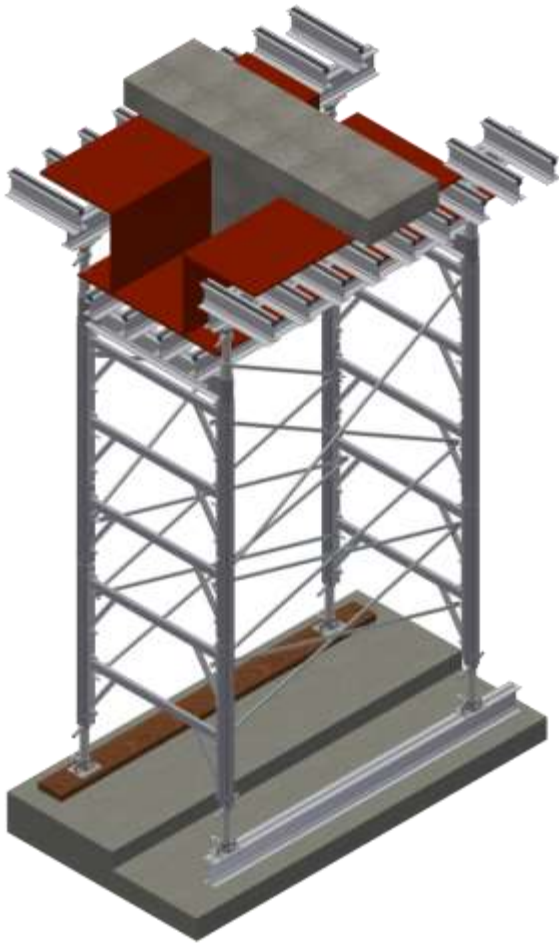

The **25K Shoring System** is primarily a hand-set system. It can also be handled with a crane, and may also be used quite successfully as a rolling or a flying system. (Consult with Hi-Lite Engineering for design)

This manual is published primarily for our customers, shoring designers and erectors this aluminum shoring system. It is intended *only as a guide* and should be used in conjunction with “generally accepted shoring design and safety regulations” in effect within the area and country of use.

The purpose of this manual is to simplify the understanding and use of the System. In this manual, each component of the 25K Shoring Systems is fully described and illustrated. The features and benefits of using the Hi-Lite 25K Shoring system are outlined in depth and key elements are cross referenced to particular components.

The Manual covers various setup arrangements of the equipment; the correct use of the system including handling and maintenance of the equipment.

Local authorities and/or a locally registered Professional Engineer should approve all drawing for construction purposes.

Barry & Dave Jackson

HI-LITE SYSTEMS

INTRODUCTION AND GENERAL GUIDELINES

PURPOSE:

TO PROVIDE TECHNICAL INFORMATION FOR THE PROPER USAGE OF THE HI-LITE'S ALUMINUM 25K FRAMES SHORING SYSTEM.

THIS INFORMATION IS INTENDED TO BE USED BY TECHNICALLY QUALIFIED INDIVIDUALS WITH APPROPRIATE KNOWLEDGE OF GENERAL FORMING AND SHORING DESIGN PRINCIPALS AND ENGINEERING DESIGN STANDARDS.

THE TECHNICAL DATA PRESENTED IN THIS MANUAL IS BASED ON THEORETICAL CALCULATIONS AND TESTING. BOTH CALCULATIONS AND TASTING HAD BEEN DONE IN ACCORDANCE WITH APPLICABLE DESIGN STANDARDS.

GENERAL GUIDELINES FOR SAFE USE OF HI-LITE ALUMINUM 25K FRAMES SHORING SYSTEM

THE FOLLOWING GUIDELINES ARE INTENDED TO ENSURE THAT DESIGNERS ADDRESS THE FOLLOWING CRITICAL ISSUES WHILE DESIGNING ANY FORMING OR SHORING APPLICATIONS OR OTHERWISE USING HI-LITE'S ALUMINUM 25K FRAMES SHORING SYSTEM.

SAFETY

HI-LITE ALUMINUM 25K FRAMES SHORING SYSTEM ARE INTENDED ONLY FOR USE BY TRAINED AND EXPERIENCED WORKERS. MISUSE OR LACK OF SUPERVISION AND / OR INSPECTION CAN CONTRIBUTE TO ACCIDENTS RESULTING IN PROPERTY DAMAGE, SERIOUS PERSONAL INJURY OR DEATHS.

HI-LITE CAN INSURE THAT EVERY PRODUCT THE MANUFACTURE AND SELL MEETS OR EXCEEDS APPLICABLE PRODUCTION AND SAFETY REQUIREMENTS. HOWEVER, THE PERFORMANCE OF A PRODUCT CAN BE GREATLY AFFECTED BY THE MANNER IN WHICH THE PRODUCT IS USED. IT IS IMPORTANT THAT THE USER BE INSTRUCTED IN THE PROPER INSTALLATION AND USE OF THE PRODUCT PRIOR TO JOB APPLICATION.

THE AMERICAN CONCRETE INSTITUTE (ACI) PUBLICATIONS, FORMWORK FOR CONCRETE (ACI SP-4) AND GUIDE TO FORMWORK FOR CONCRETE ARE EXCELLENT REFERENCE MATERIALS. THESE PUBLICATIONS ARE AVAILABLE FROM: www.concrete.org

FOR ADDITIONAL SAFETY INFORMATION, THE USER IS ADVISED TO CONSULT THE DEPARTMENT OF LABOR OCCUPATIONAL SAFETY AND HEALTH ADMINISTRATION (OSHA) ACT, PART 1910 AND 1926. AVAILABLE FROM: www.osha.gov



SAFETY FACTORS

OUR EQUIPMENT ARE CONSTANTLY TESTED TO ASSURE THE USER A HIGH STANDARD OF QUALITY. SAMPLES ARE TESTED IN HI-LITE TEST FACILITIES. THE SAFE WORKING LOADS LISTED IN THIS MANUAL WERE DETERMINED FROM THE RESULTS OF TESTING PROGRAM. THE SAFETY FACTOR APPLIED TO THE PRODUCT IS DEPENDENT ON THE DEGREE OF HAZARD OR RISK INVOLVED IN THE APPLICATION OF THE EQUIPMENT AND JOB SITE CONDITIONS, WHICH CAN OFTEN INCREASE THE DEGREE OF RISK.

CONCENTRATED LOADS, SUCH AS CONSTRUCTION MATERIALS STACKED ON THE FORMWORK, NON-SYMMETRICAL PLACEMENT OF CONCRETE, UPLIFT, IMPACT OF MACHINE DELIVERED CONCRETE, USE OF MOTORRIZED CARTS AND EXTRIME FORMWORK HEIGHT, ARE EXAMPLES THAT PRODUCE HIGH RISK FACTOR.

PLEASE CONSULT ENGINEERING DEPARTMENT OF HI-LITE-SYSTEMS IF YOU HAVE ANY OF THE ABOVE

HI-LITE TECHNICAL ASSISTANCE

IN THE SITUATONS WHERE A CONTRACTOR DOES NOT HAVE A QUALIFIED PERSON ON STAFF, HI-LITE TECHNICAL ASSISTANCE PERSONNEL ARE TRAINED TO PROVIDE SUCH SERVICES.



SHORING SAFETY GUIDLINES

SAFETY COMES FIRST

SAFETY IS EVERYONE'S RESPONSIBILITY

CONSTRUCTION PROJECTS SHOULD BE SAFE WORKPLACE. WORKERS, SUPERVISORS AND EMPLOYERS ARE ALL RESPONSIBLE FOR SAFETY.

OUR COMMITMENT TO A SAFE WORK ENVIRONMENT IS THE PRIORITY OF OUR OPERATING SYSTEM AND OUR SAFETY POLICY, EQUIPMENT SYSTEMS AND DESIGNED TO ENGAGE OUR ENTIRE WORKFORCE IN DELIVERY OF SAFE WORK ON ALL OUR AND OUR PARTNERS / CUSTOMERS PROJECTS.

ON SITE SAFTY DEPENDS UPON THE PROPER ERECTION AND SAFE USE OF SHORING AND FORMING EQUIPMENT.

HI-LITE PRODUCTS ARE DESIGNED TO HELP CONTRACTORS TO INCREASE SAFETY, PRODUCTIVITY AND EFFICIENCY.

ALL OF OUR EQUIPMENT DESIGNED ACCORDING TO NORTH AMERICAN AND INTERNATIONAL STANDARDS.

ALL THE SYSTEMS DESIGN WITH SAFETY FACTOR 2.5:1 FOR THE SHORING AND FORMING AND 4:1 FOR SCAFFOLDING.

HI LITE'S DOCUMENTATION IS CONVENIENT, EASY TO READ AND EASY TO USE. WE WILL SHOW YOU THE RIGHT WAY TO USE AND OPERATE OUR SYSTEMS. IT WILL TELL YOU ALL YOU NEED TO KNOW FOR SAFE AND EFFECTIVE WORK ON JOBSITE.



SAFETY GUIDLINES

- INSPECT ALL THE EQUIPMENT BEFORE USING.
- ALL SHORING LAYOUTS SHOULD BE AVAILABLE AND USED ON CONSTRUCTION SITE ALL THE TIME
- FOLLOW ALL THE INSTRUCTION AND INSPECT ALL SHORING AND FORMING EQUIPMENT FOR CONFORMITY WITH LAYOUT AND SAFETY PRACTICE BEFORE POUR, DURING AND AFTER POUR UNTIL CONCRETE IS SET.
- CONSULT HI-LITE SYSTEMS IF YOU HAVE ANY QUESTIONS.

HI-LITE INSTRUCTIONS FOR ASSEMBLY AND USE SHOW YOU, IN DETAILS, THE RIGHT WAY TO SET UP AND USE THE FORMWORK AND SHORING SYSTEMS. THIS INFORMATION IS AN IMPORTANT TOOL TO HELP YOU WORK WITH THE HI-LITE EQUIPMENT CORRECTLY.

UNDERSTANDING AND FOLLOWING THESE SAFETY GUIDELINES WILL IMPROVE SAFETY FOR ALL WORKERS ON THE CONSTRUCTION SITE. IF THERE ARE ANY QUESTIONS , OR IF YOU NEED ASSISTANCE IN OBTAINING ADDITIONAL TRAINING FOR YOUR EMPLOYEES, PLEASE CONTACT HI-LITE.

ASSEMBLY SAFETY RECOMMENDATIONS

ALL THE ERECTION CREW MUST BE EQUIPPED WITH HARNESSSES AND DOUBLE LANYARDS..

THE FOUNDATION MUST HAVE SUFFICIENT STRENGTH TO SAFELY SUPPORT THE ERECTED SHORING TOWERS.

SLOPPED SURFACES MUST BE COMPENSATED FOR BY LEVELING THE AREA BELOW THE BASEPLATES OR BY PROVIDING WEDGES SECURELY ATTACHED TO SILLS. SILLS SHOULD BE 2 in x 10in (50mm x 250mm) WOOD PLANKS OF SUITABLE LENGTH.



GENERAL INFORMATION

Hi-Lite Systems is the original manufacturer of the worlds very first aluminum shoring frames. As both the designer and the manufacturer of the system, we are naturally the best choice when it comes to supporting our customers, in all cases of design, layout and application of the product.

Hi-Lite's **25K Aluminum Shoring** frames weigh less than half that of comparable capacity steel frames and they can be handled by a single worker.

A 6ft high, 4ft wide 25K frame weighs 29.3 kg (66.6 lbs) compared with the same size steel frames weighing over 50 kg (110 lbs.).

Our **25K Aluminum Shoring** frames also incorporate many special labor-saving design features:

The top edge of the horizontal bar is serrated to resist slippage.

The Jet Lock (a design first) has proven itself over the years to be the fastest and most advanced lock on the market.

Hi-Lite's **25K Aluminum Shoring** is designed to accommodate various floor heights using only a single tier of frames, by utilizing specially designed extension tubes that also accept the Hi-Lite's aluminum *and* steel screw jacks.

Using extension tubes can reduce the number of frames required by as much as 50%.

With Saddle Beams the tower can support both beam and slab.

Its inherent Light weight greatly improves work person Safety and overall productivity.

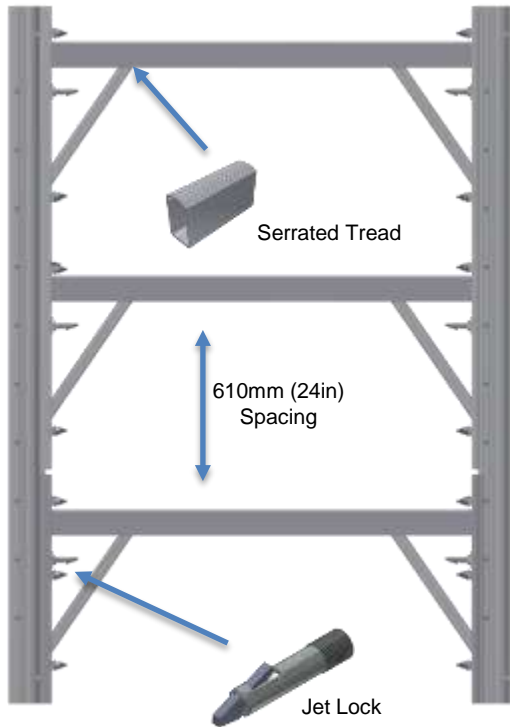

FEATURES AND BENIFITS



Our **25K Aluminum Shoring** frames also incorporate many special labor-saving design features:

- The de-mountable horizontal members are rectangular, to give the highest strength for the lowest weight.
- Hi-Lite's **25K Shoring System** is de-mountable for changing the width of the frames, leg size and capacity (25K) or to allow the legs to be used as Post Shores, using standard Screw Jacks and Extension Tubes.
- Continuous T-bolt slots on the legs allow for attachments to the legs at any location for additional bracing, lacing and/or many other optional accessories.
- The corner gusset bracing is designed to serve not only as a stiffening member, but also to protect the Jet Locks (the Cross Brace locking devices). These corner braces strengthen the frame without obstructing the function of the locks.

Note: Using extension tubes reduces the capacity of the frame. Please consult our engineering department for load capacities.

FRAMES

Hi-Lite's 25K Aluminum Shoring frames are made of a special high-strength aluminum alloy. Their **Hi**-strength / **Lite**-weight ratio greatly facilitates handling and erecting. The horizontal (serrated) ledgers make climbing safer and help to secure wood planks. Jet Locks are spaced at 605mm (2ft) centers to enable frames to be inter-braced with standard Cross Braces when erected more than one tier high. Hi-Lite's 25K Shoring System is built to safely support loads of up to 22,680kg (50,000lb) with a *Factor of Safety* of 2.5:1.

Frame capacities vary, depending the number of tiers in height, the lengths of extensions, amount of bracing, whether inter-bracing has been used, and if there are any lateral or wind loads imposed.

The normal testing configuration of the 25K Shoring System exceeds the requirements of both the CSA and the SSFI of the USA. A tower, 3 tiers high, consisting of 6ft high frames, with Screw Jacks extended 16", top and bottom, is loaded to failure. The load rating of the frames is then determined by dividing the failure load by the required Safety Factor. Holes in the frame legs, spaced at 150mm (6in) intervals, enable coarse adjustment of Extension Tubes at the top and/or bottom of the frames, to increase the overall height of the frame legs, to cope with steps or severe slopes, until a further combination of frames will make up the desired height.

Note: Using extension tubes reduces the capacity of the frame. Please consult our engineering department for load capacities.

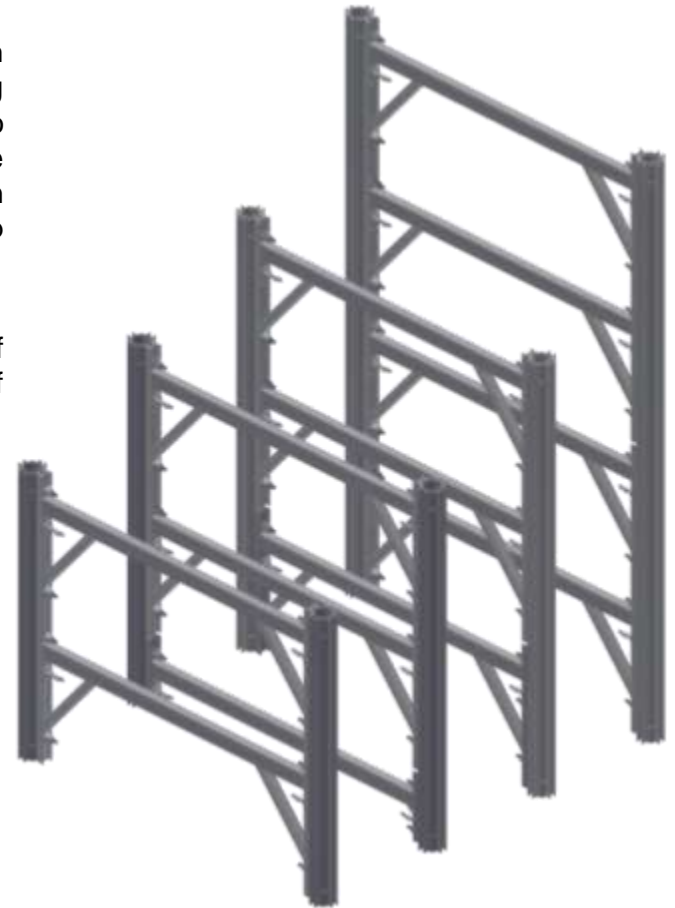

ASSEMBLY



1. Set up a level work area to assemble the frame legs and ledgers.

2. Set one leg on the work area, making sure that the holes in the leg are facing the correct way

Note hole orientation in frame leg.



3. Align the ledger assembly with the top of the frame leg.

4. Make sure the ledger is flush at the top.

Note: On all frames requiring one ledger the ledger is always flush with the top of the frame leg.

On Frames requiring two ledgers, one ledger is flush with the top and the second ledger is flush with the bottom of the frame leg.

EXTENSION TUBES



Extension Tubes readily slide into the frame legs to give additional height to the frames in 150mm (6in) increments. Screw Jacks can be inserted into the Extension Tube to provide fine adjustment. Base plates can be connected to the Extension Tubes when fine adjustment is not required. Extension Tubes for Frames are available in 900mm (36in) , 1.2m (48in) 1.8m (72in) lengths for maximum extensions of 500mm (21in), 840mm (33in) 1448mm (57in) respectively.

There are two holes and a half hole in each Extension Tube. The hole and the half hole are spaced 150mm (6in) apart to match with the holes in the frame leg, for securing the Extension Tube into the frame leg. The half hole ensures correct alignment of the Extension Tube in the frame leg. One pin of the Extension Tube Support Pin set is installed completely into the frame leg, at the required level of the bottom of the Extension Tube. The Extension Tube is placed into the leg until it rests on the pin. Then the tube is rotated until the half hole slips down onto the pin. This automatically aligns the Extension Tube in the frame leg so that the second hole lines up, and the second pin can be installed without looking or "fishing".

The single hole at the other end of the tube is intended to be used for attaching the base plates to the Extension Tube, using the connector pin.

Extension Tubes are recommended for the following purposes:

- a.) To extend the height of one or both legs of the frames.
- b.) When coarse or rapid adjustment is required.
- c.) To adjust for sloping slabs and/or grades or steps.
- d.) To allow for lowering when frames need to be lowered a large amount to clear spandrel beams, etc



SCREW JACKS AND ACCESSORIES

Hi-Lite's screw jack for the 25Kip shoring systems is 800mm (32in) long, with 600mm (24in) of adjustment. It is available in two forms (fixed and swivel base); both styles utilize our patented quick-release pin that eliminates extensive hammering of the adjusting nut to loosen the shoring under heavy load; one quick hit on the pin and the adjusting nut can be turned freely.

The Swivel Plate screw jack (SJ60SW) serves for uneven or sloped base conditions, or where it is required for forming inclined surfaces. Used on top or at the bottom, the plates are equipped with 2 T-bolts for positively locking to stringer beams.

Standard Fixed Plate screw jacks, (SJ60BPFX) with or without the quick-release pins, are also available. We recommend that they be used for Post Shores and on level floors or slabs.

The screw jack plates come with two special Hi-Lite T-Head bolts, with hex nuts designed for quick and easy locking into the continuous slot on our aluminum stringer beams. When the plate is to rest on mudsills or to be used with timber stringer material, instead of aluminum, it can be secured to the timber by nailing through the holes provided in the plate or a special U-Head can be attached to the Jack Plate. The T-Bolts retract fully into the recesses in the plate and are held in place by tightening the wing nuts. This allows for the plates to be placed on flat surfaces, or extended to re-shore without blocking, as when U-Heads are used.

The adjusting nut handle is "stepped" to allow the screw jack to be solidly centered in either an Extension Tube or the frame leg, thus assuring straight alignment and rigidity.

Hint to save time always set the adjusting nut higher than finish height before installing it in the frame leg or Extension Tube. It is always easier to lower than to raise for final setting

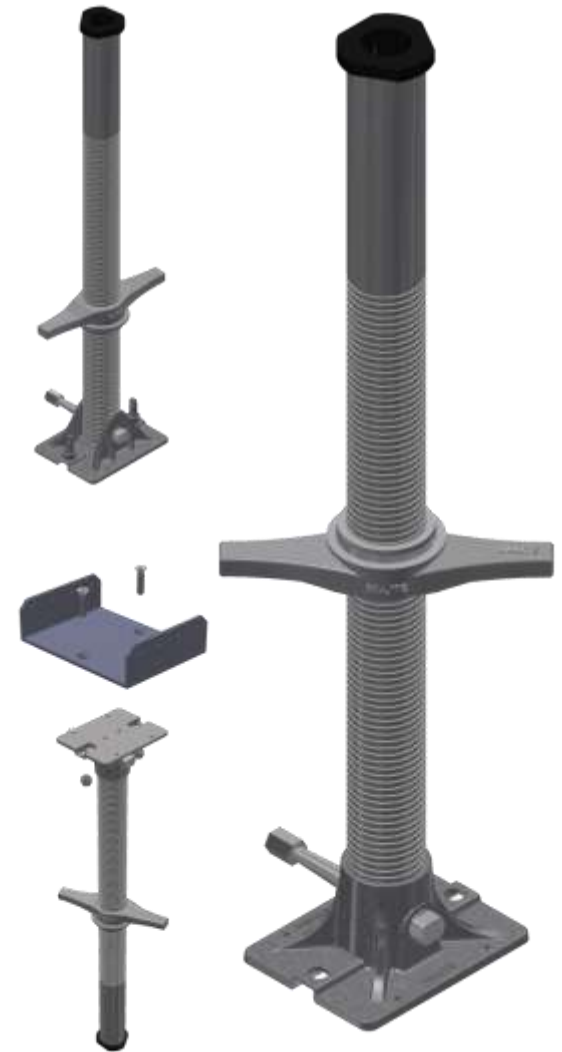

SADDLE BEAMS

Hi-Lite's Saddle Beams make drop beam or pre-cast beams easy to deal with, enabling stripping the slab without loosening or disturbing the support under the concrete drop beams. The Saddle Beam facilitates supporting poured-in-place concrete drop beams within the frame, at one level, leaving the legs free to accommodate Extension Tubes and Screw Jacks to support the slab formwork, at another level. It also allows for easy stripping of the slab form without disturbing the concrete drop beam soffit forms.

Saddle Beams are made from lengths of standard 184mm (7-1/4in), high-strength Aluminum Beams, with special brackets at each end to enable them to transfer the load of concrete drop beams to the frame legs.

The Saddle Beam is installed at the top of a tower with Extension Tubes locked into the frame legs and protruding through the Saddle Beam end brackets. If wide poured-in-place concrete beams need to be supported, longer Saddle Beams can be adapted between two frames over the Cross Braces.



REFER TO THE LOAD CHARTS FOR DETERMINING THE CAPACITIES OF THE VARIOUS CONFIGURATIONS OF SADDLE BEAMS.

25SB4

25K Saddle Beam – 4'
10.1 kgs / 22.2 lbs

25SB5

25K Saddle Beam – 5'
12.0 kgs / 26.4 lbs

25SB6

25K Saddle Beam – 6'
13.8 kgs / 30.5 lbs

25SB7

25K Saddle Beam – 7'
15.7 kgs / 34.7 lbs



JET LOCKS

Jet Lock Spacing

The spacing of the Jet Locks permits inter-frame bracing, using standard size Cross Braces. This additional brace can add considerable rigidity to a multi-tier tower. The inter-frame brace is often a standard 600mm (2ft) Cross Brace by the length required. Jet Locks can also be spaced on 1.2m (4ft) modules on higher frames, allowing continuous 1.2m (4ft) by any length Cross Brace can also be used continually on a high tower, also giving full capacity when continuously braced.

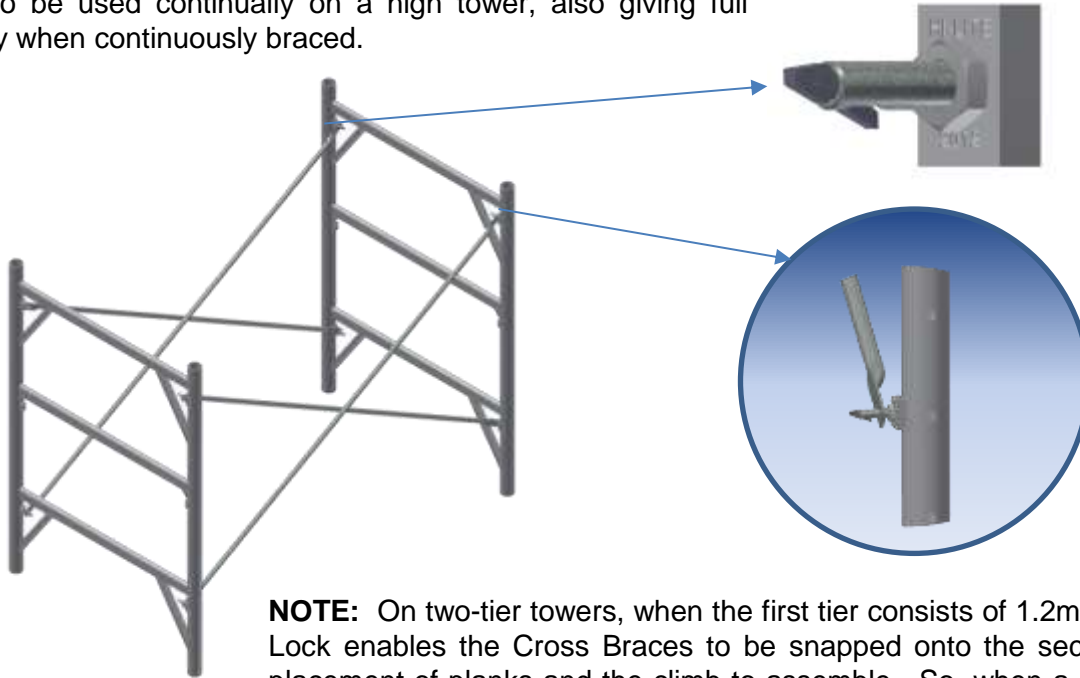

Jet Lock Assembly

This unique fastener is standard on all Hi-Lite shoring frames. The Jet Lock is installed at appropriate locations to allow Cross Braces to be attached to the frames quickly and securely. Jet Locks are easily replaced in the field (if necessary) as they are held in place by standard hex jam nuts.

To install Cross Braces on the Jet Locks, simply open up the braces to position their holes over the Jet Locks, then push to snap on. The Jet Lock spring is made of stainless steel, for long, rust-free life. Jet Locks can be replaced with special bolts and nuts, if required, for positive solid connections of the Cross Braces to the frames. These special bolts are available, but they are seldom used, because the connection using the Jet Lock is very secure.

NOTE: On two-tier towers, when the first tier consists of 1.2m (4ft) high frames, the spring action of the Jet Lock enables the Cross Braces to be snapped onto the second tier of frames, from the ground, saving placement of planks and the climb to assemble. So, when a 1.2m (4ft) high frame is used together with a 1.8m (6ft) high frame, we recommend the 1.2m(4ft) frame be located at the bottom and the 1.8m (6ft) high frame on top with Screw Jacks in before placement.

HI-LITE FRAME BRACING REQUIREMENTS

INTRODUCTION:

Shoring towers are required to support vertical loads as well as horizontal loads. The vertical loads are due to concrete weight (dead load), the self weight of the equipment (live load) as well as workers and their tools. Horizontal loads can be induced due to wind loads, sloped slabs or dynamic loads on the shoring equipment.

The magnitude of the load and the methods of calculating the loads on the various components of the shoring equipment are discussed in detail in the “Design Methodology” section of the manual.

This section will deal with the bracing requirements for the shoring towers and will provide guidelines for different types of applications.

TERMS AND DEFINITIONS

DIAGONAL BRACING¹:

Supplementary formwork members designed to resist lateral loads.

HORIZONTAL LACING¹:

Horizontal bracing members attached to shores (or frames) to reduce their unsupported length, thereby increasing load capacity and stability.

BRACING²:

Bracing means a system of secondary members which connect frames, shores or panels of falsework system to provide stability against lateral movement.

LACING²:

Lacing means members required to reduce the unsupported length of columns.

REFERENCES:

1 – ACI 347-04 – a guide to formwork for concrete.

2 – CSA 269.1 – Falsework for Construction.

For our purposes we will refer to any type of bracing/lacing as “bracing”.

Bracing components are comprised of 1.9” OD Tubes (steel or aluminum) and clamps that are specifically designed to attach to the frame legs on one end and to the tube on the other end. Clamps are either fixed at 90 degrees or swivel to allow for various bracing requirements.

A complete section on Tube and Clamp is available in the Engineering Design Manual.

GENERAL REQUIREMENTS FOR BRACING:

STABILITY BRACING:

Bracing of any type of shoring towers/scaffolding towers must meet the stability requirement which states that the minimum base to height ratio, in any direction of otherwise un-braced free standing towers cannot exceed the following:

- A) 3:1 for Canada
- B) 4:1 for U.S.A.

Refer to illustration 1 for stability bracing requirements.

LATERAL BRACING:

Lateral bracing is a design requirement and is utilized to maintain the capacity of the shoring towers when the height of the tower exceeds the specified un-supported length (rated height) of the test specimen. For Hi-Lite Frames the requirement is every third frame for a 6'-0" high frames and every second frame for applications utilizing the 8'-0" high frames. (Refer to illustrations 2 through 5 for examples)

BRACING FOR HORIZONTAL LOAD:

Bracing is used to transfer the horizontal forces from the shoring towers to the ground or to the permanent structure. (Refer to illustration 6 for examples)

GENERAL RECOMMENDATIONS

- Lateral bracing shall be designed by a qualified structural engineer in accordance with National Building Codes and Local regulations.
- Towers exceeding the allowable height-to-base ratio shall be braced in both directions.
- Clamping of external bracing shall be at the intersection of vertical legs with the bracing tube.
- Do not connect bracing tubes to the frame's ledgers.
- Whenever possible, the horizontal bracing shall be tied to permanent structures such as walls, columns.
- If no walls or columns are present, guying can be used as an alternative.

IMPORTANT:

The temporary shoring structures shall be structurally analyzed to include all lateral loads including wind pressure, lateral loads due to motorized equipment, lateral load components due to inclined supports or live and dead loads, etc

If required, consult Hi-Lite Systems Engineering Department.

As a Guideline: In Canada, horizontal bracing is placed at a height not exceeding 3 times the minimum base width. In the USA, except for some states, the rule is 4 times the minimum base width.

BE SURE TO CHECK ALL RELEVANT CODES.

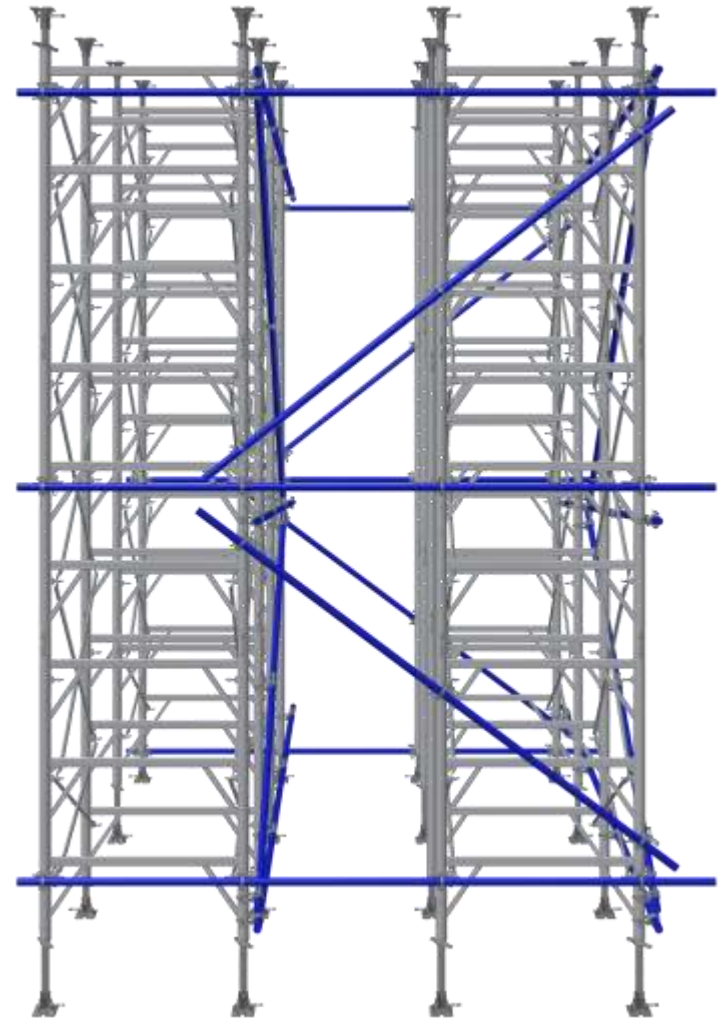

SLOPPING SURFACES

- Lateral bracing shall be designed by a qualified structural engineer in accordance with National Building Codes and Local regulations.
- Towers exceeding the allowable height-to-base ratio shall be braced in both directions.
- Clamping of external bracing shall be at the intersection of vertical legs with the bracing tube.
- Do not connect bracing tubes to the frame's ledgers.
- Whenever possible, the horizontal bracing shall be tied to permanent structures such as walls, columns.
- If no walls or columns are present, guying can be used as an alternative.

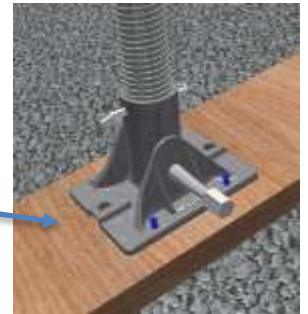
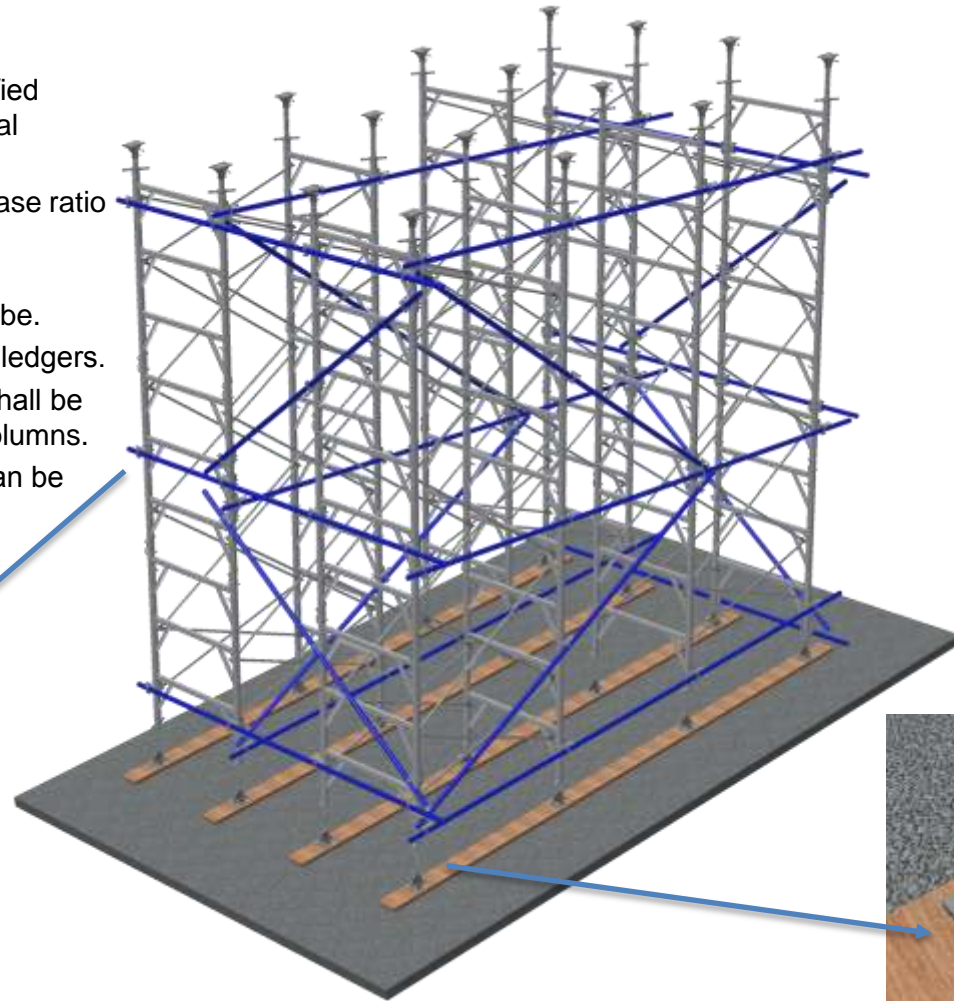

BE SURE TO CHECK ALL RELEVANT CODES.

Base Plate nailed directly to mudsill or slab

SAFETY MAINTAINING FULL LEG LOAD

The continuous T-bolt slots on the 25K Aluminum Shoring system frame legs provide a perfect means of connecting additional Cross Braces to the frames to provide additional lateral stability, often eliminating the need for tube-and-clamp bracing. The T-bolts can be installed into the brace end holes. Straight or cross braces then can be installed readily at any point on the length of the frame leg. The location of the T-bolt slots on all four sides of the leg permits stability bracing and/or lacing in all directions.

Note: The forces induced in tower legs by added bracing must be taken into account in the design of the support system. Consult your Engineer for details.

Do not clamp to rectangular horizontal frame ledgers.

We recommend that additional lateral stability bracing be installed at the mid-height of 7.3m(24ft) to 9.1m(30ft) high towers, and every 5.5m(18ft) [3 frames] if higher.

The towers should be sufficiently diagonally braced to prevent lateral movement, where the walls or columns are not poured before the deck.

Tube-and-clamp can also be used to provide additional stability bracing in both directions. Clamps should be used at every intersection of the bracing tubes with the frame legs. The horizontal tubes should, if possible, be tied to or butted against the permanent structure (such as walls or columns).

Note: If towers are inter-braced and sufficiently Cross Braced between towers, tube-and-clamp may only be needed in one direction or may not be required at all. Consult Hi-Lite Systems or an experienced layout engineer. Guying can also be an alternative for providing additional stability bracing

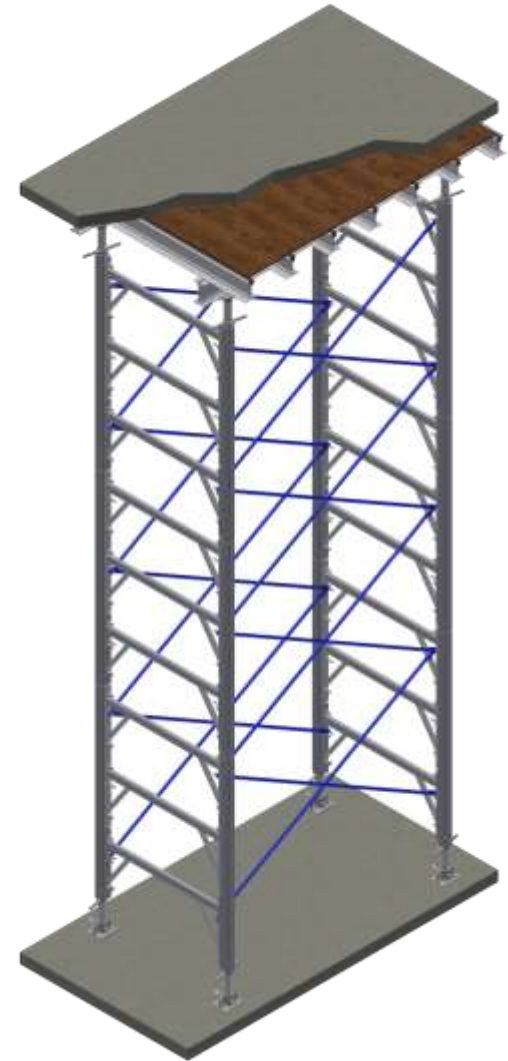

INTER-FRAME BRACING

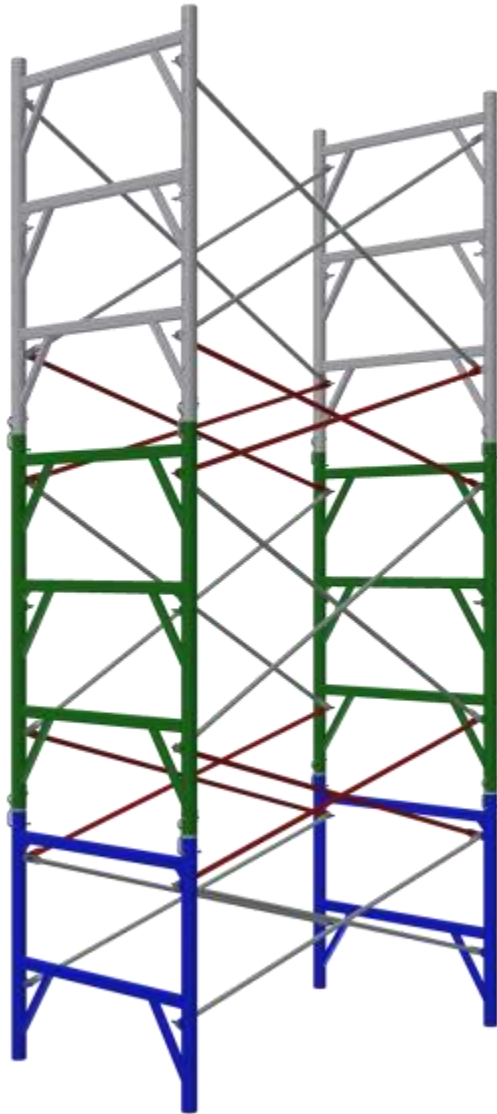

The inter-frame brace utilizes a combination of standard 600mm (2ft) Cross Brace and 1.2m (4ft) Cross Braces.

Jet Locks can also be spaced on 1.2m (4ft) modules on higher frames, allowing continuous 1.2m (4ft) by any length Cross Brace can also be used continually on a high tower, also giving full capacity when continuously braced.

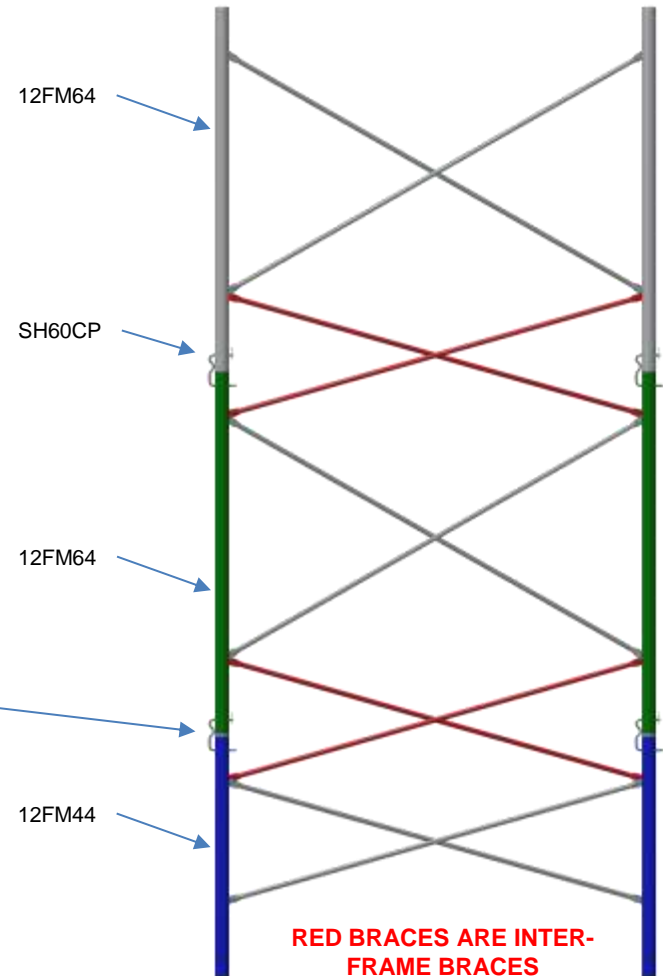
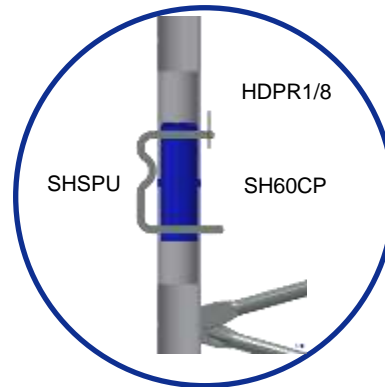

INTER-FRAME BRACING ALTERNATIVE

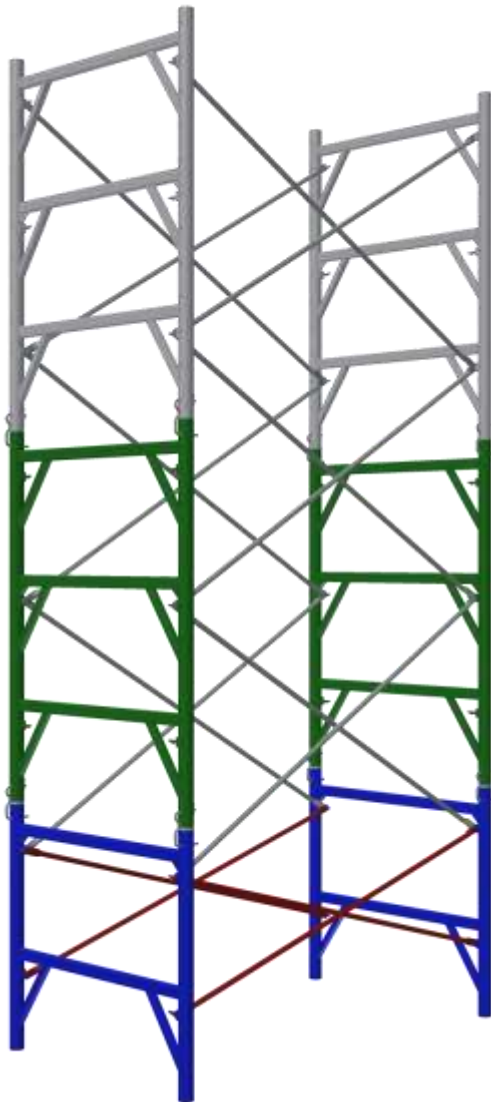

This inter-frame brace utilizes a standard 1.2m (4ft) Cross Brace by the length required. Jet Locks can also be spaced on 1.2m (4ft) modules on higher frames, allowing continuous 1.2m (4ft) by any length Cross Brace can also be used continually on a high tower, also giving full capacity when continuously braced.

Braces both lower and upper frame, creating a full continuous brace.

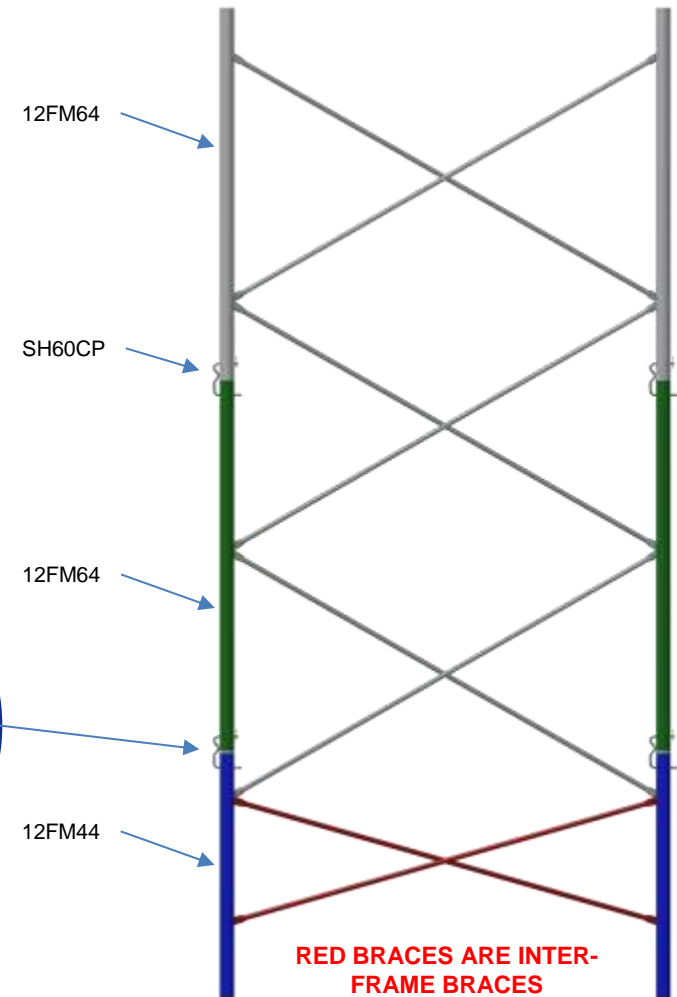
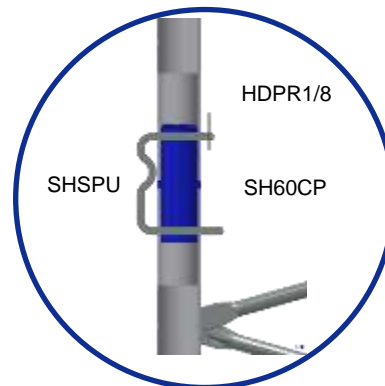

SAFETY ERECTING TOWERS

Note: The forces induced in tower legs by added bracing must be taken into account in the design of the support system. Consult your Engineer for details.

DO NOT CLAMP TO RECTANGULAR HORIZONTAL FRAME LEDGERS.

We recommend that additional lateral stability bracing be installed at the mid-height of 7.3m(24ft) to 9.1m(30ft) high towers, and every 5.5m(18ft) [3 frames] if higher.

The towers should be sufficiently diagonally braced to prevent lateral movement, where the walls or columns are not poured before the deck.

Tube-and-clamp can also be used to provide additional stability bracing in both directions. Clamps should be used at every intersection of the bracing tubes with the frame legs. The horizontal tubes should, if possible, be tied to or butted against the permanent structure (such as walls or columns).

Note: If towers are inter-braced and sufficiently Cross Braced between towers, tube-and-clamp may only be needed in one direction or may not be required at all. Consult Hi-Lite Systems or an experienced layout engineer. Guying can also be an alternative for providing additional stability bracing

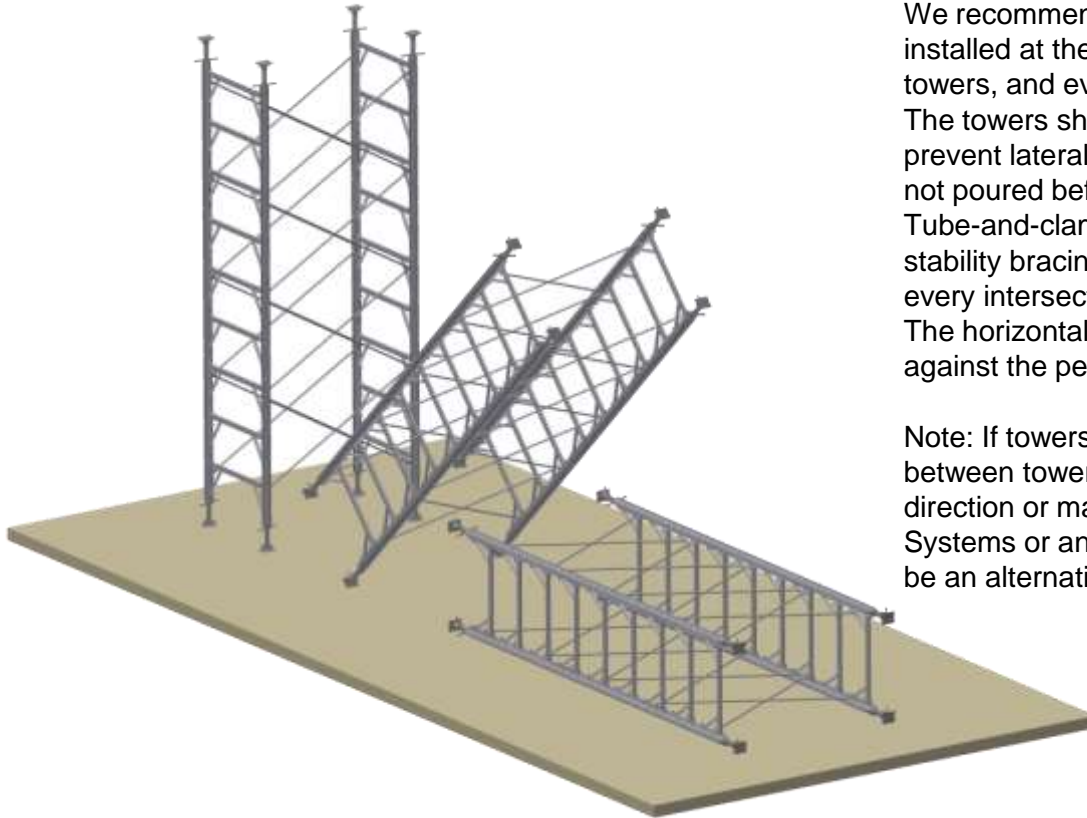

ECONOMICAL AND SAFE SET-UP PROCEDURES

The most economical setup occurs where Screw Jack adjustment is only needed at one end of the tower as shown in illustration.

When erecting on level concrete, etc. always use the jacks on top and the Extension Tubes at the bottom. This saves considerable time in leveling each tower, provides for easy movement into location, and to the next location, often without reassemble. This works well on towers even up to 4 frames high, providing the base is solid and level. If working from mudsills or a sloping foundation, always use the Screw Jacks on the bottom.

Always set the Screw Jacks 12mm (1/2in) to 25mm (1in) high before installing, so that when it is time to level the deck, you just tap the adjusting nut handle to level. If you have the room, and are setting 2 or 3 frames high, assemble on the ground and raise as a unit, again with Screw Jacks already installed in the tops of the frame legs. This, when it is possible to carry out, will reduce man-hours by over 70%.

NOTE: Considerable time (man-hours) can be saved with the Hi-Lite's Aluminum Shoring Systems, providing some planning goes into the erecting procedures. Ideas include using Extension Tubes and plates on the bottom. If the tower consists of one 4ft high frame and one 6ft high frame, put the 4ft high frame on the bottom and the 6ft high frame at the top, with Screw Jacks already installed in the tops of the legs -- if you have two strong men. Otherwise, the Screw Jacks will have to be installed later. By putting the 1.2m (4ft) frame at the bottom, you will also be able to set the braces from the ground, saving plank handling and climbing to set braces and Screw Jacks.

Description of Various Set-Up Combinations

Hi-Lite' *Aluminum Shoring Systems* are very versatile in allowing many different set-ups for various conditions and applications. A number of various set-ups for one-frame-high towers are illustrated below and on the following pages.

IMPORTANT: Always keep extension to a minimum for safety and use the highest frame possible for maximum load. If you have to extend, example IL-8 is the best way to set up or IL-11 if on mud sills or uneven ground.

CONSULT HI-LITE IF YOU HAVE ANY QUESTIONS ABOUT SET-UP OR LOAD-CARRYING CAPABILITY.

SET-UP EXAMPLES

ILLUSTRATION 7

height range: min - 1370mm (54in) to max - 1850mm (73in) **fine** adjustment at top only

GOOD SET-UP. USED WHERE THE TOWER SITS ON LEVEL CONCRETE.

NOTE: Always try to use approximately the same amount of extension at the top as on the bottom. We recommend that when 1.5m(60in) and 2.1m (72in) extension tubes are used in frames, they should be braced in both directions

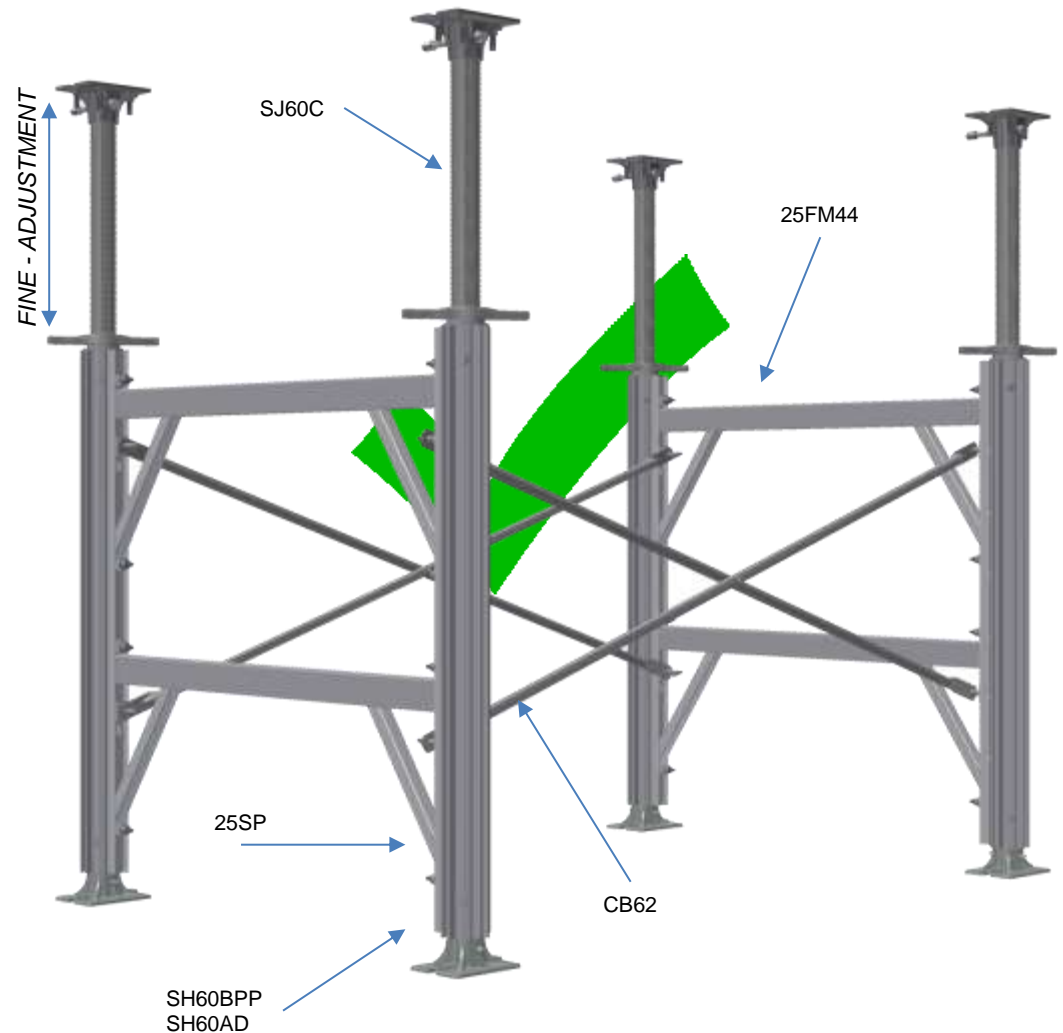

SET-UP EXAMPLES

ILLUSTRATION 8

height range: min - 1830mm (72in) to max - 2430mm (96in) **fine** adjustment at top, **coarse** adjustment at bottom

GOOD SET-UP. USED WHERE THE TOWER SITS ON LEVEL CONCRETE.

NOTE: Always try to use approximately the same amount of extension at the top as on the bottom. We recommend that when 1.5m(60in) and 2.1m (72in) extension tubes are used in frames, they should be braced in both directions

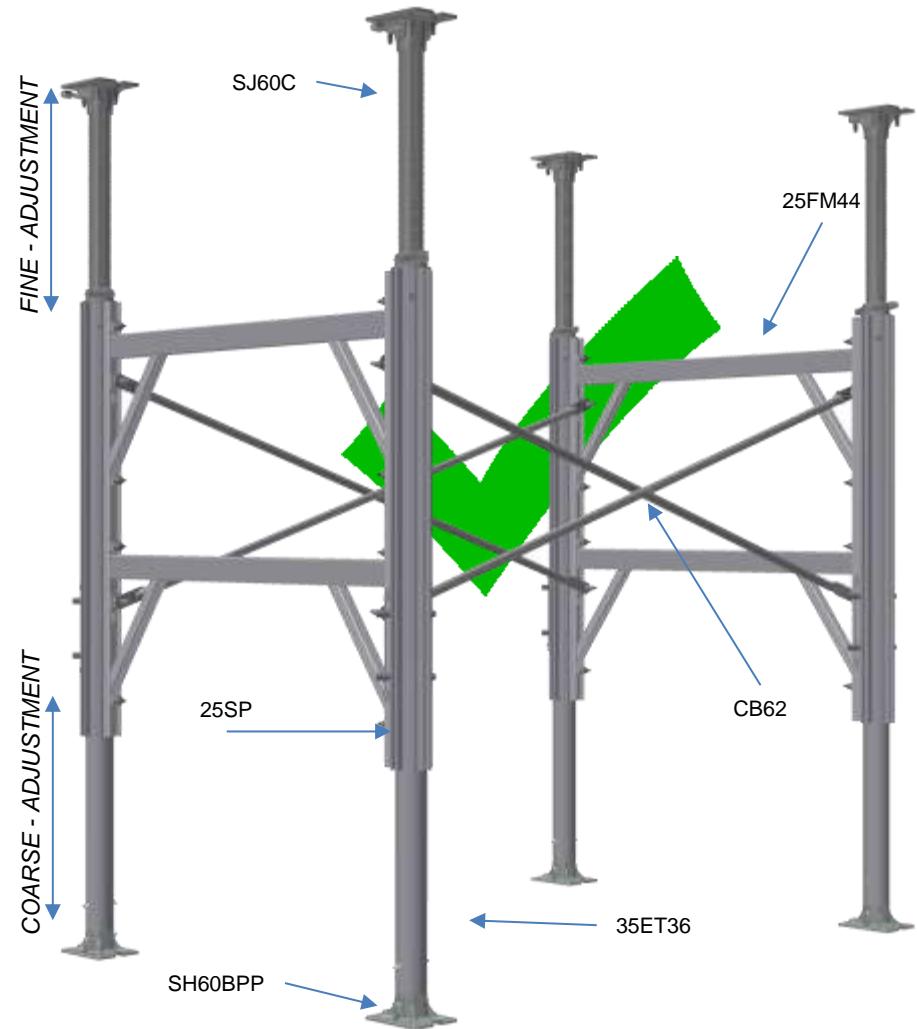

SET-UP EXAMPLES

ILLUSTRATION 9

height range: min - 1830mm (72in) to
max - 2430mm (96in) **coarse**
adjustment at top, **fine** adjustment at
bottom

**NOTE: GOOD SET-UP: USED WHERE THE
TOWER SITS ON LEVEL CONCRETE AND A FAIR
AMOUNT OF ADJUSTMENT IS REQUIRED.**

**NOTE: Always try to use approximately the same
amount of extension at the top as on the bottom.
We recommend that when 1.5m(60in) and 2.1m
(72in) extension tubes are used in frames, they
should be braced in both directions**

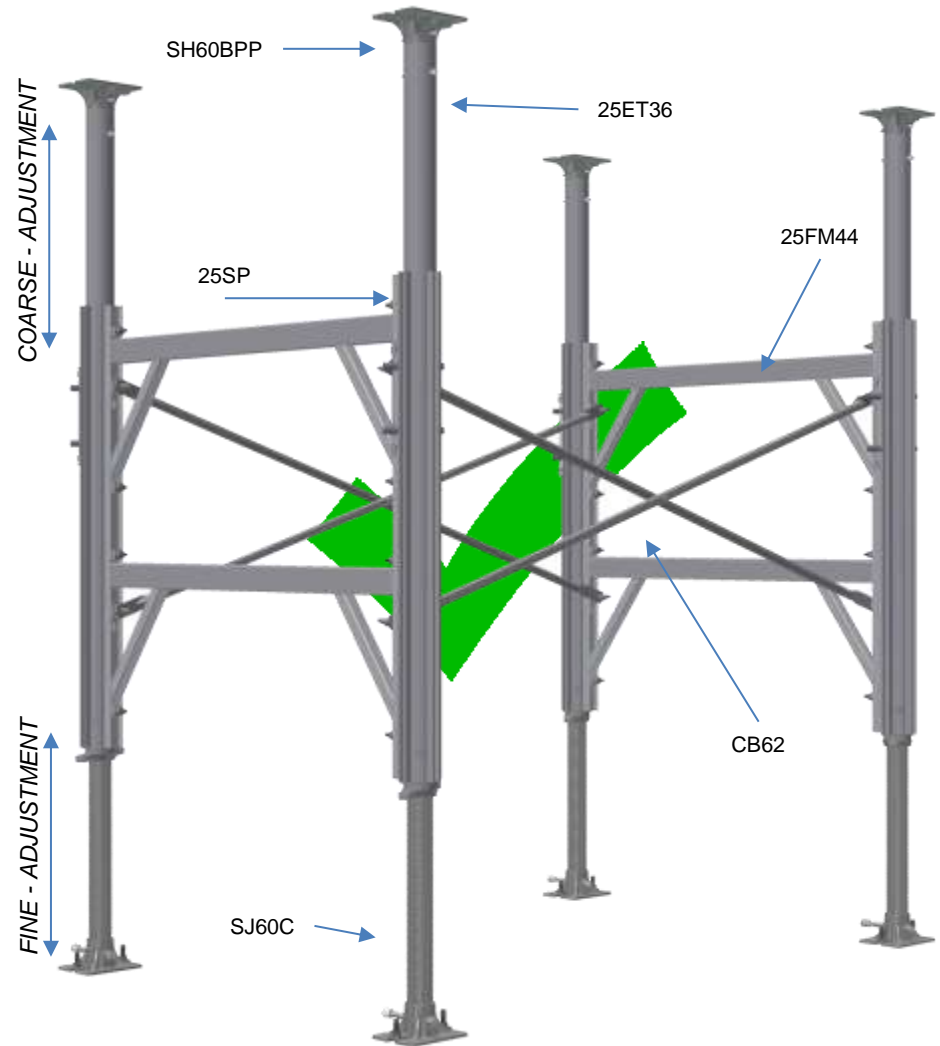

SET-UP EXAMPLES

ILLUSTRATION 10



ILLUSTRATION 11

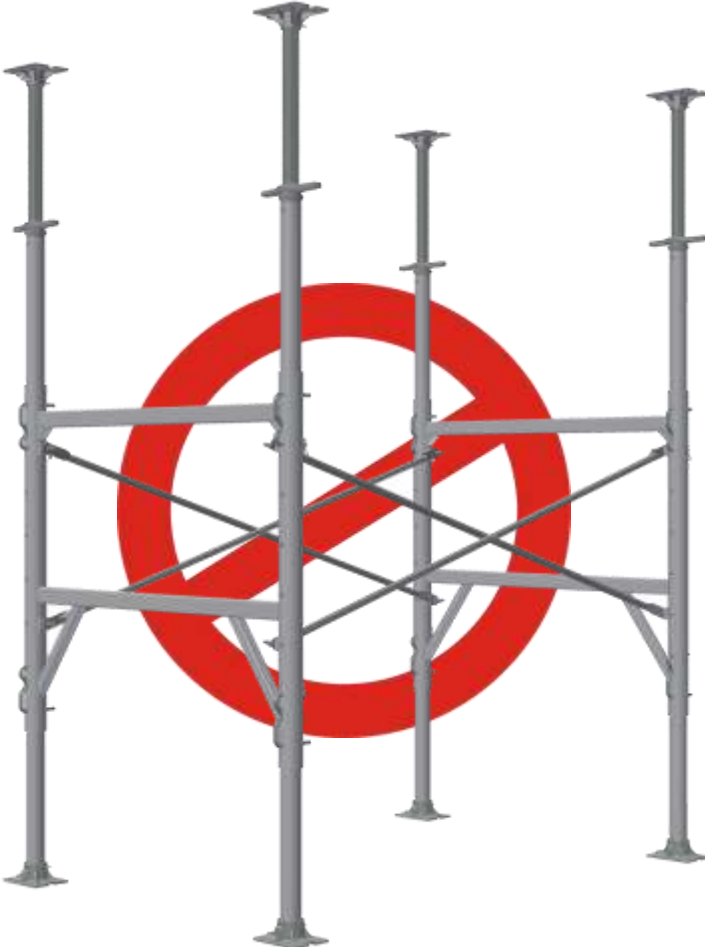

BAD SET-UP(s) (UNBALANCED), FOR USE WHERE THE TOWER SITS ON LEVEL CONCRETE AND REQUIRES EXTENSION AT ONE END.



EXTENSION TUBES

1. Extension Tube with Screw Jack on top
2. Extension Tube with **incorrect** placement of U-Pin
3. Extension Tube with Base Plate on top

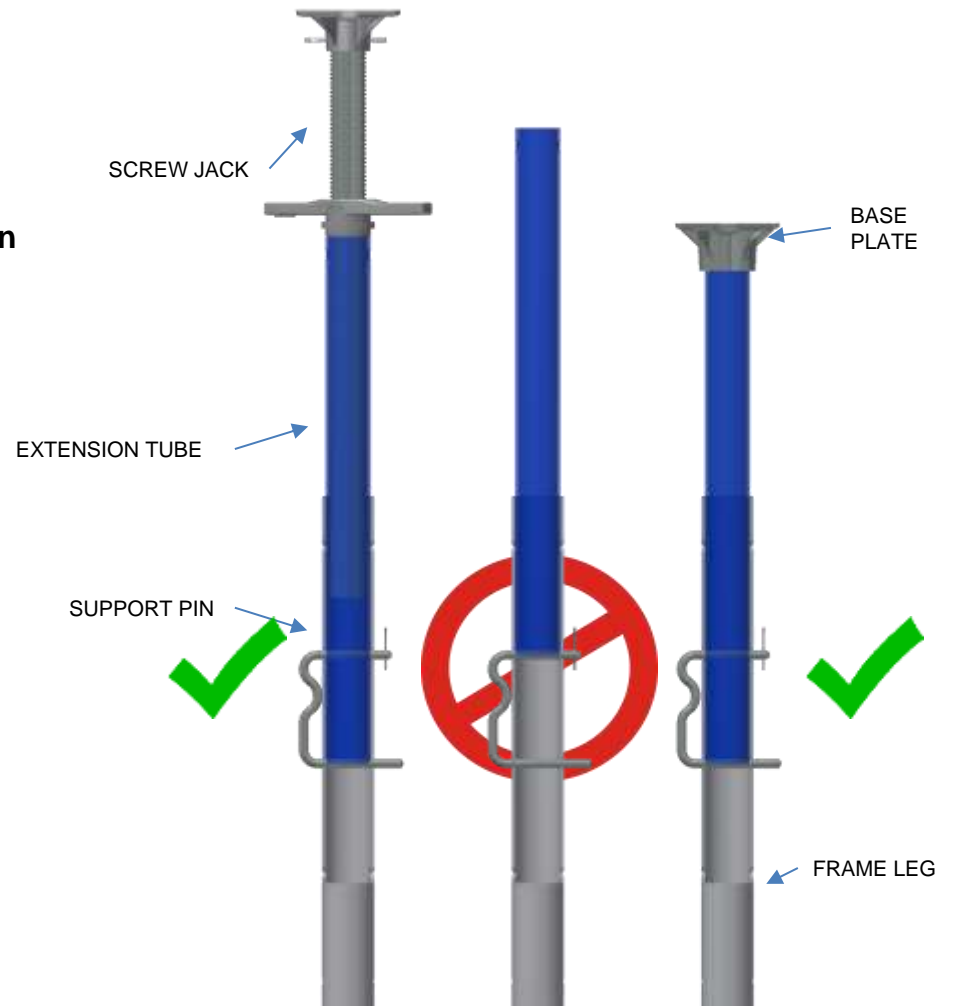

ALWAYS ENSURE THAT U-PIN IS PROPERLY ENGAGED INTO BOTH THE FULL AND ½ HOLE OF THE EXTENSION TUBE TO PROVIDE EQUAL DISTRIBUTION OF LOAD BEARING ON THE U-PIN AND FRAME LEG.

FALL PREVENTION

ALL THE ERECTION CREW MUST BE EQUIPPED WITH HARNESSES AND DOUBLE LANYARDS.

HARNESSES SHOULD BE SAFELY ATTACHED TO HORIZONTAL MEMBERS OF THE FRAME IN THE LOCATIONS SHOWN ON DIAGRAM

NOTE: IT IS VERY IMPORTANT TO NOTE THAT THE HANGING POINTS SHOULD BE BETWEEN THE KNEE BRACE AND THE FRAME LEG – INDICATED IN THE ATTACHED SKETCH. IT SHOULD NEVER BE FROM THE MIDDLE OF THE FRAME.

25K 4 foot HIGH FRAME

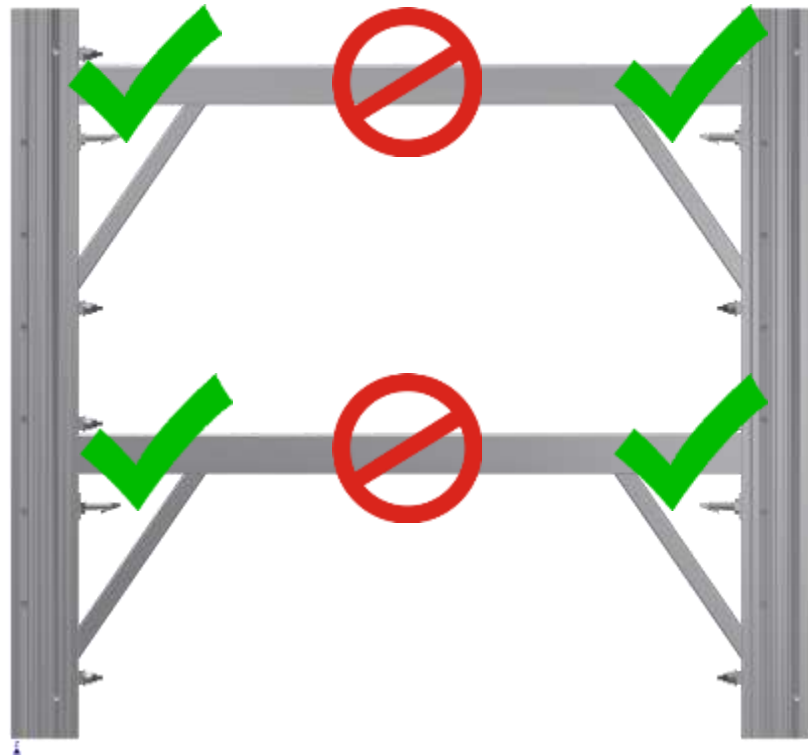

FALL PREVENTION

ALL THE ERECTION CREW MUST BE EQUIPPED WITH HARNESSES AND DOUBLE LANYARDS.

HARNESSES SHOULD BE SAFELY ATTACHED TO HORIZONTAL MEMBERS OF THE FRAME IN THE LOCATIONS SHOWN ON DIAGRAM

NOTE: IT IS VERY IMPORTANT TO NOTE THAT THE HANGING POINTS SHOULD BE BETWEEN THE KNEE BRACE AND THE FRAME LEG – INDICATED IN THE ATTACHED SKETCH. IT SHOULD NEVER BE FROM THE MIDDLE OF THE FRAME.

25K 5 foot HIGH FRAME

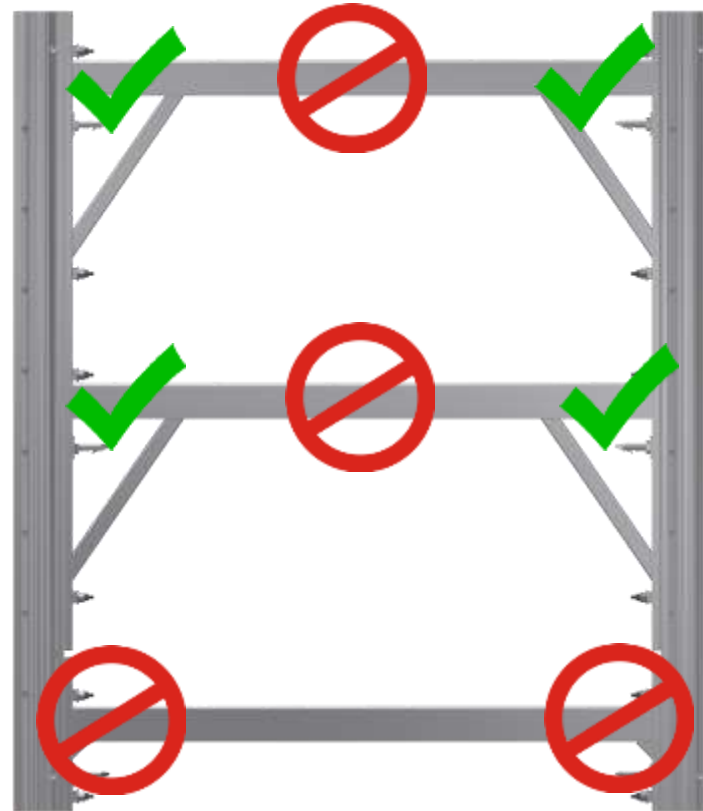

FALL PREVENTION

ALL THE ERECTION CREW MUST BE EQUIPPED WITH HARNESSES AND DOUBLE LANYARDS.

HARNESSES SHOULD BE SAFELY ATTACHED TO HORIZONTAL MEMBERS OF THE FRAME IN THE LOCATIONS SHOWN ON DIAGRAM

NOTE: IT IS VERY IMPORTANT TO NOTE THAT THE HANGING POINTS SHOULD BE BETWEEN THE KNEE BRACE AND THE FRAME LEG – INDICATED IN THE ATTACHED SKETCH. IT SHOULD NEVER BE FROM THE MIDDLE OF THE FRAME.

25K 6 foot HIGH FRAME

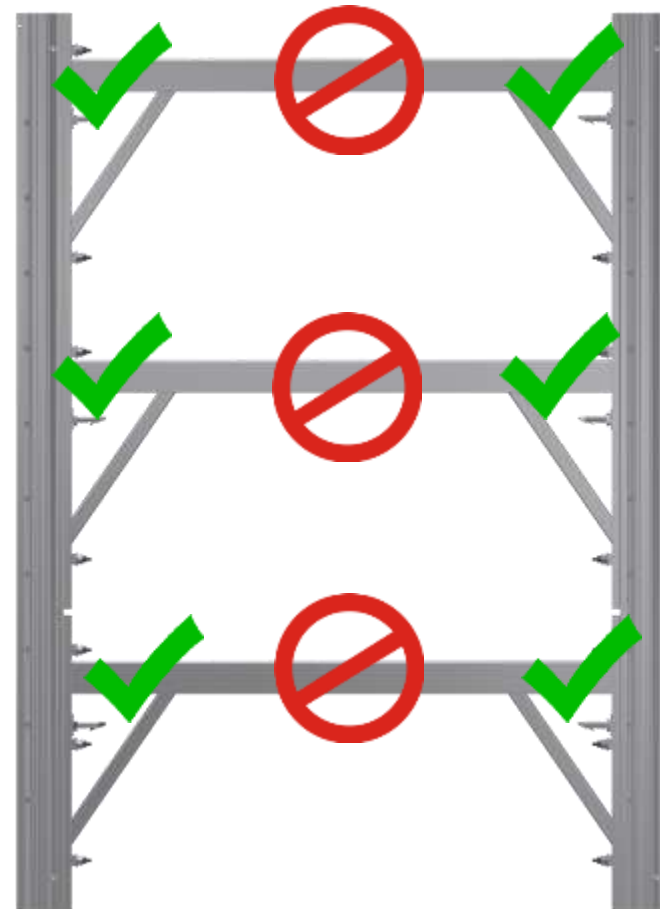

FALL PREVENTION

ALL THE ERECTION CREW MUST BE EQUIPPED WITH HARNESSSES AND DOUBLE LANYARDS.

HARNESSSES SHOULD BE SAFELY ATTACHED TO HORIZONTAL MEMBERS OF THE FRAME IN THE LOCATIONS SHOWN ON DIAGRAM

NOTE: IT IS VERY IMPORTANT TO NOTE THAT THE HANGING POINTS SHOULD BE BETWEEN THE KNEE BRACE AND THE FRAME LEG – INDICATED IN THE ATTACHED SKETCH. IT SHOULD NEVER BE FROM THE MIDDLE OF THE FRAME.

25K 8 foot HIGH FRAME

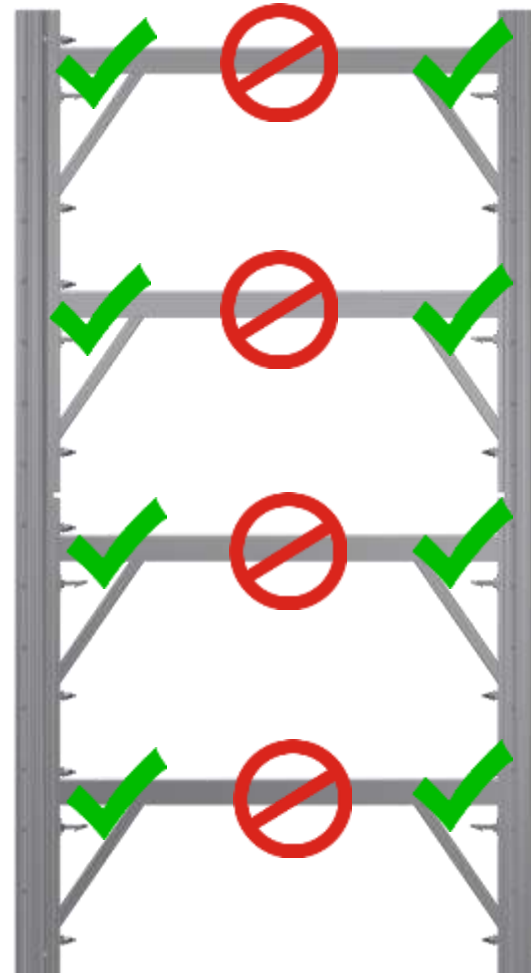

EQUIPMENT HANDLING AND ASSEMBLY SAFETY SUGGESTIONS

A recommendable way of storing the frame is No more than 50 frames should be stacked in a column, we suggest stacking 30.frames banding and then handling with a forklift.

Cross braces, extension tubes and similar equipment should be checked for damage, bundled and banded in their respective sizes, counted and ready for shipment. Screw-jacks should be palletized and banded in lots of 100 with red and blue stabilizers separated.

ASSEMBLY

Because of the light weight of this system, it is possible and sometimes advisable to assemble the equipment on the ground first and then raise the setup ladder style. This cuts down considerable on erection time with towers 2 and 3 frame high. Be sure that all components are properly locked in place .so that nothing will fall away during the raising. This is accomplished by using extension support pins through the frame legs with nails or locking pins.

Two men can easily raise 3-6' high frames with Jack in. (Set Jacks 1/2 to 1" high for ease of leveling)

UNSAFE PRACTICES

Screw jack plates not evenly loaded cause eccentric loading on the frame leg.

NOTE:

It is extremely advisable that both 'T' bolts be locked onto the stringer whenever possible.

Do not concentrate load at edges of plates. This could cause bending of plates and could result in a collapse. There should be very little gap left between stringers.

All stringers should be joined over the centre of the screw-jacks, or extension tube plates. Never join mudsills under a screw jack.'

Make sure all screw jack adjustment nuts are tight. If a screw jack nut is not tight then that frame leg will take less than its design load and other screw-jacks and legs will carry more than they are supposed to and possibly a collapse may result~ or the stringer beam may deflect at the loose screw jack and this will result in the slab being uneven at that point.



Sales and Manufacturing Facilities

HI-LITE SYSTEMS / JASCO SALES INC
 Mississauga, Ontario, Canada
 +1-905-677-4032

TARGET HI-LITE
 Abu Dhabi, United Arab Emirates
 +971-2-6727452

SHOR-SCAF USA INC.
 Las Vegas, Nevada, U.S.A.

HI-LITE CHINA
 Tianjin, China

HI-LITE INDIA
 Chennai, India

Supported by five regional offices.

Hi-Lite products are utilized by contractors in over thirty countries around the world.

Experience

the Hi-Lite Advantage.

Experience

the Hi-Lite Advantage.

Call 1-877-HILITE-1 (1-877-445-4831) to request a demonstration of our Hi-Lite Aluminum Systems.

**Hi-Lite Systems
International Inc.**

1680 Bonhill Road
Mississauga, Ontario
Canada L5T 1C8

Tel: 1-905-677-4032

Toll-free: 1-877-HILITE-1 [North America]
(1-877-445-4831)

Fax: 1-905-677-4542

Web Site: www.hi-lite-systems.com

E-mail: hilite@hi-lite-systems.com

